

Level 2 Electric Vehicle Charging Station

Cat. No. EVB32

Installation Instructions



DI-001-EVB32-00A-X1

RATINGS	
Voltage	120/208V 60Hz 3-phase Y (L1-G/L2-G - 120V, L1-L2 - 208V) 120/240V 60Hz Split-phase (L1-G/L2-G - 120V, L1-L2 - 240V)
Current	32A
NOTE: Charging Station operates on 120/208V or 120/240V circuit only. Does not operate on 120V circuit.	

WARNINGS AND CAUTIONS:

- If the information in this instruction sheet is not followed exactly, **SHOCK OR FIRE MAY RESULT CAUSING PROPERTY DAMAGE, PERSONAL INJURY OR DEATH.**
 - For outdoor installations, hard wire connection is required to maintain NEMA 4 weatherproof rating.
 - Hard-wire installation and service must be performed by an electrician.
 - **IMPORTANT:** Save these instructions for local electrical inspector's use and future reference.
- NOTE:** Unit operates on 208V or 240V circuit, it will not operate on 120V.

INTRODUCTION

Thank you for purchasing the Level 2 32A Electric Vehicle Charging Station. This installation sheet includes the latest information at the time of printing. Leviton reserves the right to make changes to this product without further notice. Changes or modifications to this product by other than an authorized service provider could void the product warranty. If you have questions about the use of this product, contact your Customer Service Representative. Refer to the Customer Support section located in these instructions.

Important Notes to the Installer:

- Read all instructions contained in these installation instructions before installing hard-wired version of the Charging Station.
- The installer is responsible for verifying that the wall structure/surface will safely support a total load of 200 lbs.
- Observe all governing codes and ordinances.
- Be sure to leave these instructions with the consumer.

Important Notes to the Consumer:

- Keep these instructions with your User Guide for future reference.
- Ensure your Charging Station is installed properly by an electrician or service technician.

PLUG-IN INSTALLATION

NOTE: The Plug-In Charging Station **must** be installed with a Leviton Pre-Wire Kit (**sold separately**). Failure to do so means the station no longer complies with its UL listing. The listing requires the station be removable without tools. Refer to Pre-Wire Kit instructions first if a mounting location has not been established.

1. Locate the slot above the thumb screw. Locate the four Mounting Buttons on the back of the Charging Station (**see Figure 1**).
2. Align the slot with the guide pin, and the four Mounting Buttons with the four key holes on the Mounting Bracket.
3. Once aligned, gently press the Charging Station onto the Mounting Bracket.
4. Allow the Charging Station to slowly slide down into place.
5. Tighten the thumb screw to secure Charging Station to Mounting Bracket.

Proceed to **POWER CHARGING STATION** section.

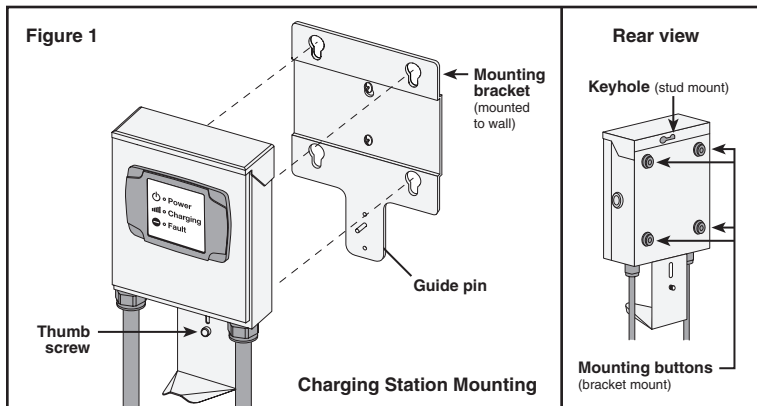

MOUNTING LOCATION

The Charging Station should be located in close proximity to the electric vehicle's parking location. The Charging Station must connect to the electric vehicle via a Charge Connector and Charge Connector Cord. **NOTE:** The path from the Charging Station to the electric vehicle should be free from obstacles, and be within the range of the Charge Connector Cord (18 or 25 foot standard lengths).

The recommended mounting height of the Charging Station is not to exceed 48 inches, but not less than 42 inches. This provides convenient access and operation of the Charging Station, and meets ADA requirements for access.

NOTE: The area surrounding the Charging Station enclosure should be free from obstruction. Recommended clearance around station: 5" above and 3-1/2" on either side.

MOUNTING INSTALLATION

Select a location that is suitable for mounting the Charging Station based on the criteria presented in the MOUNTING LOCATION section.

For stud walls, the Charging Station can be mounted to bare studs or walls with drywall. For metal stud or solid wall applications, you will need to procure wall anchors for the Charging Station, capable of supporting a maximum allowable load of 200 lbs. For solid wall applications you will also need to procure appropriate conduit and appropriate wall anchors.

NOTE: A hard-wired installation can be mounted directly to the wall, or with the use of the Mounting Bracket included in the Pre-Wire Kit (purchased separately). To mount directly to a stud wall, follow directions below:

TO INSTALL:

1. To install the charging station by use of mounting screws, first remove the 4 mounting buttons from the charging station (**See Figure 1 Rear View**).
2. Locate a wall stud in the area in which the Charging Station will be installed (**See Figure 2**).
3. Measure 48" up from the floor and place a mark on the stud that will be used for mounting.
4. For wood studs, drill a 3/16" diameter pilot hole, 2-1/2" deep, directly in the middle of the stud. For metal studs, follow manufacturer's instructions for wall anchor installation.
5. Loosely fasten a #14 x 2-1/2"L wood screw by turning the screw into the pilot hole until approximately 1/2" length remains. Hook the Charging Station onto the screw using the top keyhole slot. Secure in place by installing an additional screw through the bottom set screw hole.
6. Cut off and remove Warranty Void Padlock (**See Figure 5**).
7. Use a standard screwdriver to open the Enclosure Door from the side to gain access and tighten top mounting screw. Proceed with hard-wired installation.

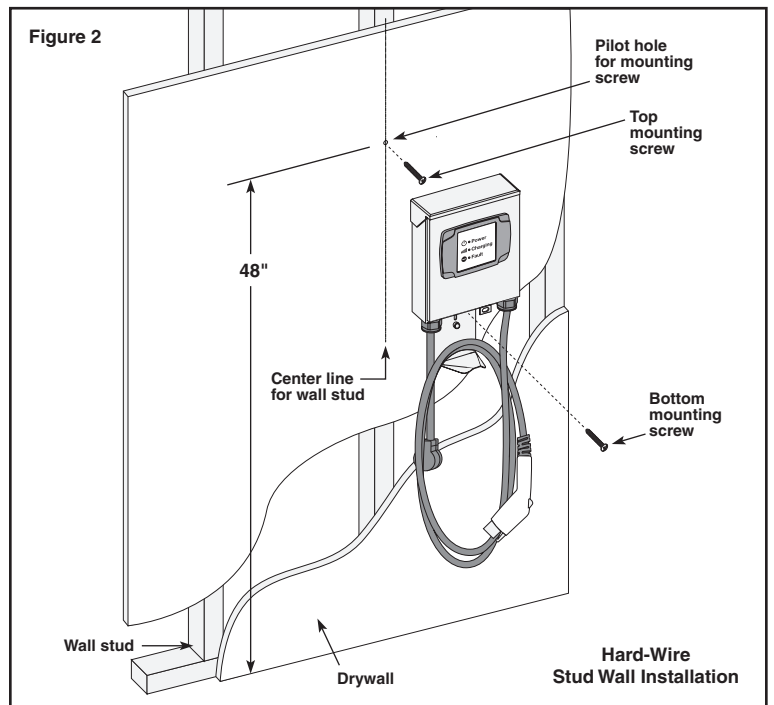

HARD-WIRE INSTALLATION

Gather the required tools and parts before starting installation. Be sure to follow manufacturer's instructions for use of any tools or parts used for this installation.

Tools:

- Drill with 3/16" bit
- Stud finder
- Level
- Scratch awl
- #2 and #3 Phillips screwdriver
- Utility knife
- Measuring tape
- Wire cutters/strippers
- Keyhole saw

Additional Parts (not included):

- Copper electrical cable (10AWG minimum)
- Conduit
- 40A Circuit Breaker
- Strain relief (if applicable)
- #14 wood mounting screws (2) - stud mount
- H100-TB Hub (or engineering equivalent)

For Metal Stud Applications:

- Wall anchors capable of supporting a maximum allowable load of 200 lbs.

For Solid Wall Applications:

- Wall anchors capable of supporting a maximum allowable load of 200 lbs.
- Appropriate conduit and applicable mounting hardware.

LIMITED THREE (3) YEAR WARRANTY AND EXCLUSIONS

Leviton warrants to the original consumer purchaser and not for the benefit of anyone else that this product at the time of its sale by Leviton is free of defects in materials and workmanship under normal and proper use for three years from the purchase date. Leviton's only obligation is to correct such defects by repair or replacement, at its option, if within such three year period the product is returned prepaid, with proof of purchase date, and a description of the problem to **Leviton Mfg. Co., Inc. 201 North Service Road, Melville, N.Y. 11747**. This warranty excludes and there is disclaimed liability for labor for removal of this product or reinstallation. This warranty is void if this product is installed improperly or in an improper environment, overloaded, misused, opened, abused, or altered in any manner, or is not used under normal operating conditions or not in accordance with any labels or instructions. **There are no other or implied warranties of any kind, including merchantability and fitness for a particular purpose**, but if any implied warranty is required by the applicable jurisdiction, the duration of any such implied warranty, including merchantability and fitness for a particular purpose, is limited to three years. **Leviton is not liable for incidental, indirect, special, or consequential damages, including without limitation, damage to, or loss of use of, any equipment, lost sales or profits or delay or failure to perform this warranty obligation.** The remedies provided herein are the exclusive remedies under this warranty, whether based on contract, tort or otherwise.

HARD-WIRING CHARGING STATION

WARNING: HARD-WIRE INSTALLATION AND SERVICE MUST BE PERFORMED BY AN ELECTRICIAN.

WARNING: TO AVOID FIRE, SHOCK, OR DEATH **TURN OFF POWER** AT CIRCUIT BREAKER OR FUSE AND TEST THAT POWER IS OFF BEFORE WIRING!

CAUTION: USE THIS DEVICE WITH **COPPER OR COPPER CLAD WIRE ONLY**.

CAUTION: A 40A BREAKER SHALL BE USED. **DO NOT** USE WIRE LESS THAN 10 AWG REFER TO **TABLE 1** FOR PROPER TORQUE VALUES.

1. If necessary use a standard screwdriver to open the Enclosure Door from the side to gain access for wiring.
2. Remove (2) Wire Nuts and loosen ground wire from terminal block. Remove pre-installed hub and disconnect existing plug assembly. Install a H100-TB hub.
3. Verify that appropriate 40A circuit breaker, conduit and wire gauge have been selected.
4. Run an individual circuit as per the National Electric Code and local building codes. The circuit must reach the bottom of the Charging Station with an additional 5" of loose wire to terminate the connection on the inside of Charging Station.
NOTE: Use appropriate strain relief for conduit if applicable.
5. Feed conduit through hub. Leave approximately 5" of wire lead in the Charging Station. Secure conduit to hub using proper conduit fitting. The use of a reducer may be required based on conduit fitting selected (**see Figure 3**).
6. Strip wires 1/2". Insert ground wire into terminal block and secure wire by tightening terminal screws (Refer to **TABLE 1** for proper torque values). Connect Line 1 and Line 2 with wire nuts (**see Figure 4**).
7. Close Enclosure Door and secure lock with screwdriver. Place new Warranty Void Padlock onto the locking tab (**see Figure 5**).

TABLE 1	
Wire Gauge	Torque
6 CU/AL	45 in/lbs.
8 CU/AL	40 in/lbs.
10 CU/AL	35 in/lbs.

Figure 3 - Wiring Charging Station

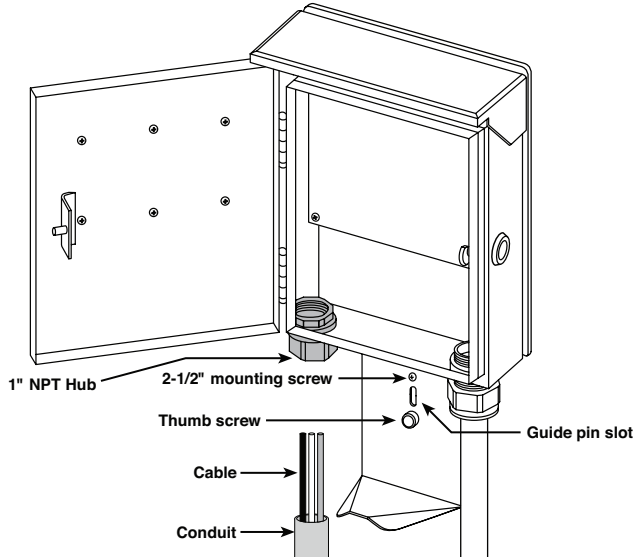
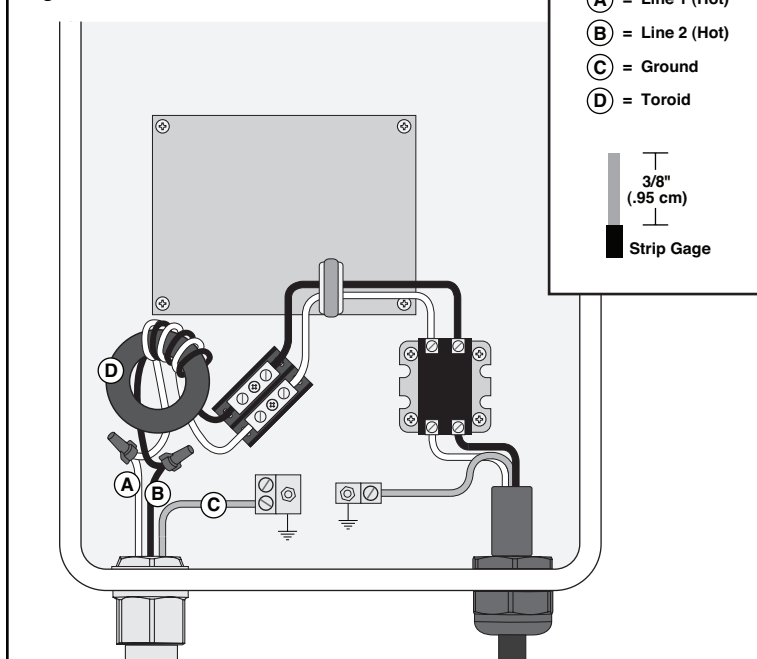

Figure 4 - Terminal Block Connection



CUSTOMER SUPPORT

Call our Customer Support Hotline at 1-877-338-7473. If your call is made after business hours or on weekends, please leave your name, telephone number, the unit's serial number, and a brief description of the problem. These can be found on the label on the left side of the Charging Station enclosure. A Customer Service Representative will call back at the earliest opportunity.

Many questions and answers can be found in our knowledge base community. Just go to leviton.com and click on the Knowledgebase link, or go directly to leviton.com/evgreen.

Wiring Diagram - 208V

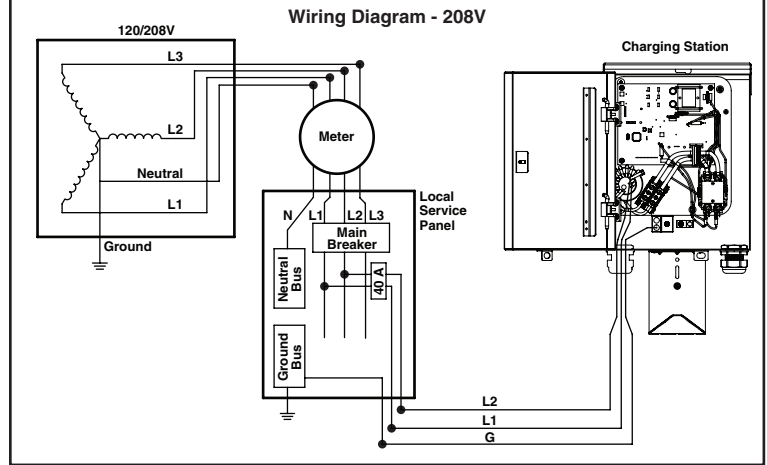

Wiring Diagram - 240V

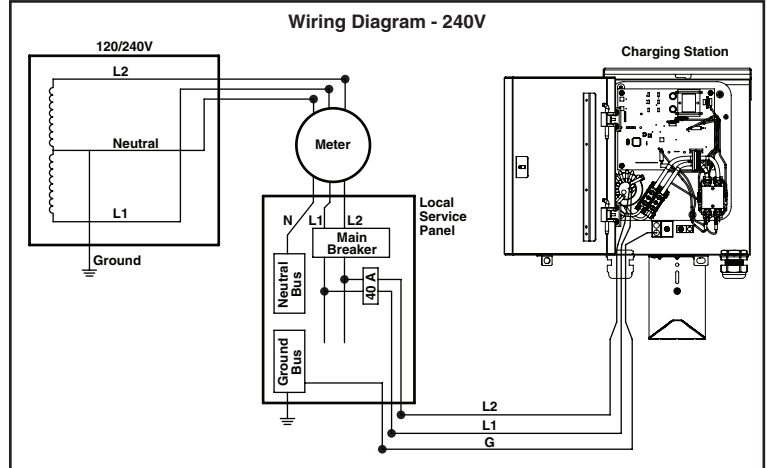
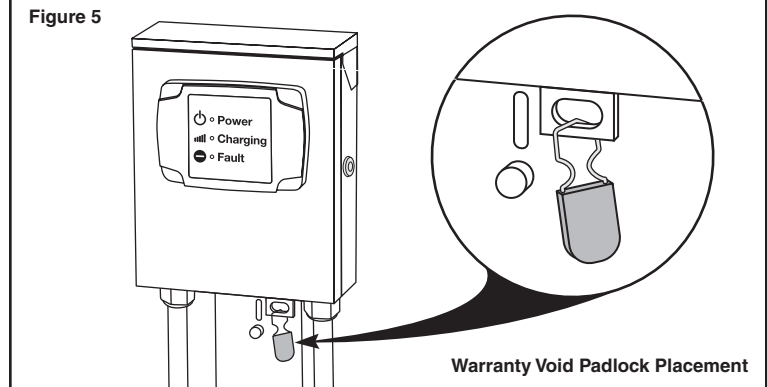

Figure 5



POWER CHARGING STATION

NOTE: For Hard-Wire Installation, restore power at circuit breaker or fuse. For Plug-In Installation, simply plug the AC Supply Cord into the NEMA 6-50R grounded 50A, 240VAC electrical outlet supplied with the pre-wire kit and in good working condition to start power up sequence.

Power Up Sequence

- The Power, Charging and Fault LEDs will illuminate momentarily followed by just the Power LED. The Charging Station will then initiate a self-test sequence.

NOTE: DO NOT plug the Charge Connector into the vehicle prior to the self-test; this may cause the Charging Station to go into Cold Load Pick-up, and delay charging.

- The Power LED will flash for approximately 3 seconds indicating the self-test, and then the Power LED will remain lit, indicating that the Charging Station is ready for use.

Refer to Level 2, 32A Electric Vehicle Charging Station User Guide for operation.